

UFO LED HIGH BAY LIGHT

DIAMOND SERIES



100W | 150W | 200W | 240W

Specification

Input Voltage: AC100-277V @50/60Hz

Material: Aluminum + PC

Light Source: SMD2835

Driver: ZH POWER

CCT: 3000K / 4000K / 5000K / 5700K / 6500K

CRI: 70RA / 80RA

Optics: Lens

Beam Angle: 60° / 90° / 120°

Installation: Suspension, Wall Mounted, Ceiling Mounted

IK Rating: IK08

IP Rating: IP65

Finish: Black

Operating Temperature: -30°C - 45°C

Lifespan: L80B10: 80,000 Hrs

Warranty: 5 Years

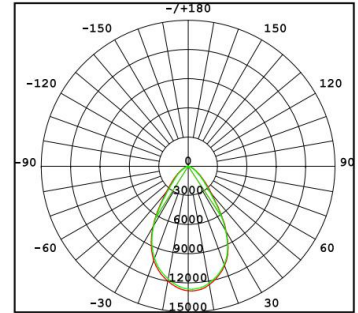
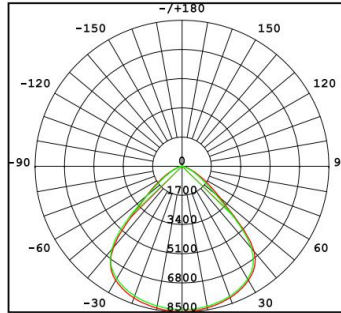
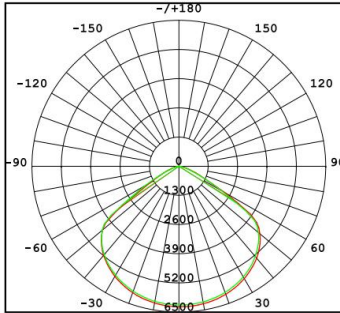

Model No.	Power	Size	Qty/CTN	G.W.	Measurement
DIAMOND-100W	100W	Ø262*H168	1pc	2.0kg	280*280*145
DIAMOND-150W	150W	Ø301*H168	1pc	2.6kg	320*320*145
DIAMOND-200W	200W	Ø350*H168	1pc	3.5kg	370*370*145
DIAMOND-240W	240W	Ø350*H168	1pc	3.5kg	370*370*145

Features

High Quality Material

Sanan SMD2835 chips and ZH Power driver, the special rectangle illuminance for goods in a certain area.



Customized

More functions such as DALI /0-10V Dim / Sensor / Power Selectable / CCT Selectable / Emergency / Zigbee / TUYA smart

Installation

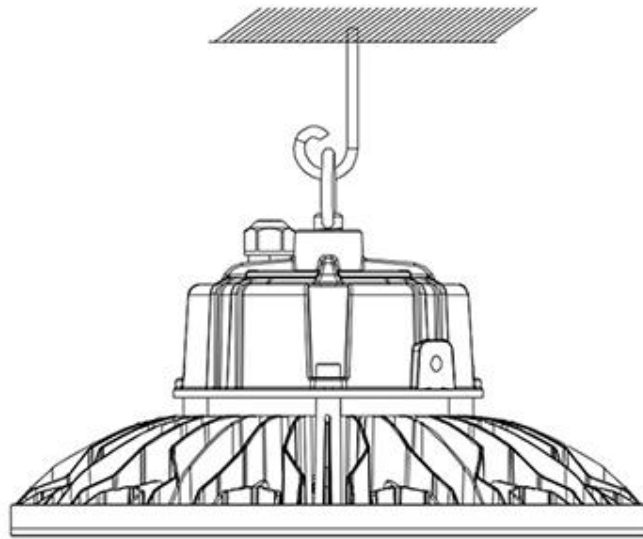

Suspension

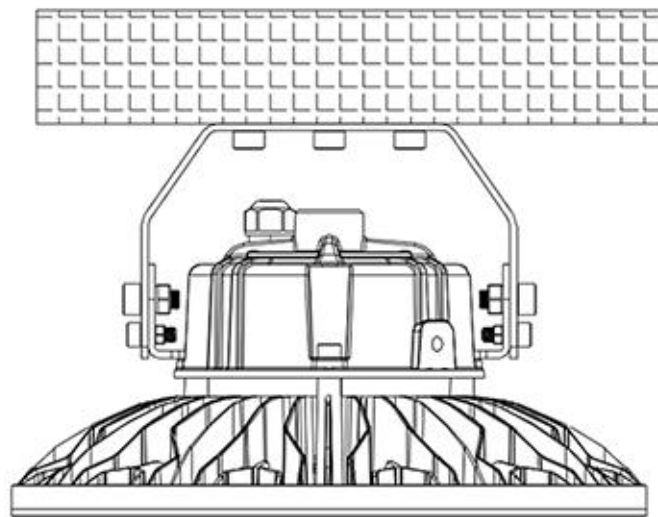

Ceiling Mounted

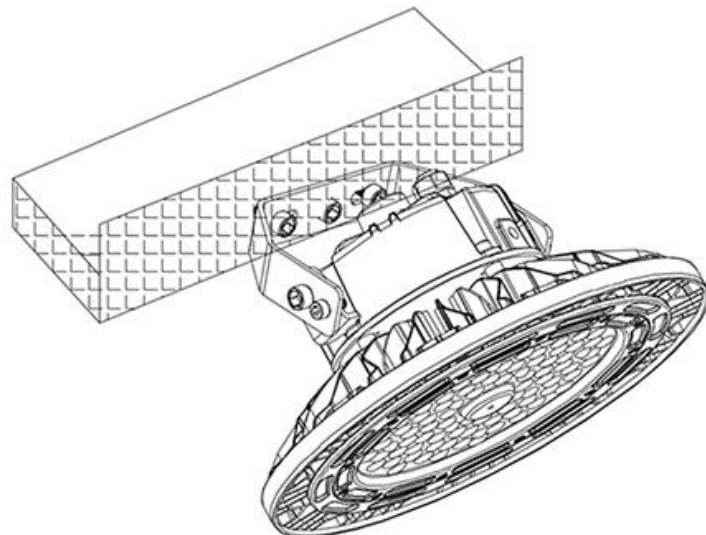

Wall Mounted

Application

